



eagle

NEWS

The newsletter for the nuclear & nuclear medicine professional



INSIDE THIS ISSUE

- 02. [Aquila Contract Wins](#)
- 03. [UKTI Showcase, Pelletron Hot Cells,
a word from Mark Shaw](#)
- 04. [Getinge-La Calhène, AWE](#)
- 05. [Progress on contracts](#)
- 06. [Canberra UK & Aquila](#)
- 07. [Aquila & Hargeaves
Drew Corbett,](#)
- 08. [Events
Contact Aquila](#)

ISSUE NUMBER:

04



“ I CAN TRULY SAY THAT THIS IS THE MOST DYNAMIC AND EXCITING PERIOD I HAVE EXPERIENCED IN THIS INDUSTRY.



We are managing to keep up with the invitation to work directly with Tier 1s and support Tier 2s for larger packages of nuclear work. Having now spent over 30 years in the nuclear industry, I can truly say that this is the most dynamic and exciting period I have experienced in this industry. We have many new young engineers joining Aquila, from diverse industries including motor sport and marine engineering. The nuclear industry serves us well because Aquila can offer established solutions, tried and tested in the past. This de-risks projects and makes the outturn costs more competitive. This is extremely important to all of us, as UK taxpayers.

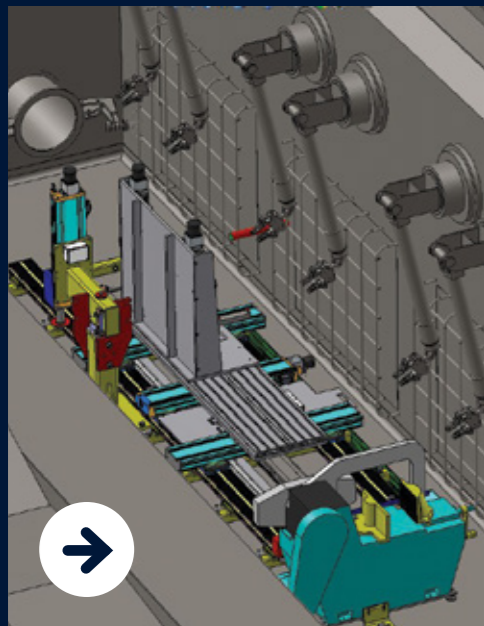

CONTRACT WINS



Aquila Nuclear Engineering Ltd, part of the Calder Group, the £165m pan European engineering group, has recently been awarded 3 contracts from NNL for the design and build of rigs to be used within shielded caves. These rigs and equipment include:-

RESIDUAL STRESS RIG

This system is used to accurately bond, strain gauge assemblies onto irradiated components, employing a master slave manipulator (MSM) within a shielded cave. Using NNL's functional requirements as the design input, Aquila presented concept designs, verified process requirements, developed engineering schemes and will take this on to manufacture, assembly and test.

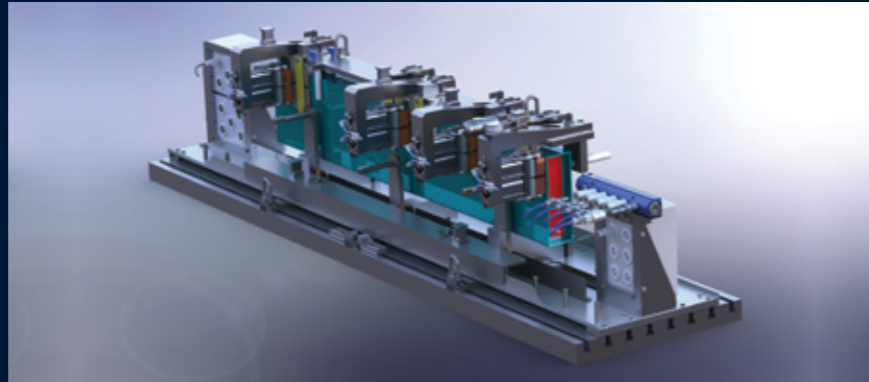

ANALYSIS BREAKDOWN EQUIPMENT

Aquila is developing a range of equipment to receive and process irradiated components to allow for the size reduction, preparation and inspection. The equipment consists of an XY gantry, complete with a Z drive slitting saw machining head, a Z drive and rotation unit and a large cut off saw. The equipment is being developed in conjunction with NNL in order to achieve the best integrated package of works.

XY HYDRAULIC PRESS

Aquila is modifying a proprietary hydraulic press to be operated by a Master Slave Manipulator (MSM). The equipment receives a component and via remotely controlled X and Y drives, accurately positions the component to allow samples to be punched out at specific locations for further inspection and testing.

Nick Clark - Senior Buyer at NNL, said, "It was obvious from the tender submissions that the team at Aquila had read and understood our functional requirements and converted these requirements into a feasible, fully priced design solution at the bid stage."

Dave Barker - CEO of Aquila, said, "These contract awards were another great example of Aquila using its depth of remote handling knowledge in the nuclear industry, during the tendering stage. Design during tender, is just one of five USPs which set Aquila apart from its competition in the nuclear industry."

UKTI SHOWCASE, PELLETRON HOT CELLS



AQUILA WAS ASKED TO PRESENT ITS INNOVATION STRATEGY AT THE UKTI CIVIL NUCLEAR ENERGY SHOWCASE

Dave Barker, CEO of Aquila Nuclear Engineering Ltd, presented at the UKTI Nuclear Energy Showcase in London. The event was promoted and supported by DECC and the Nuclear Industries Association. Baroness Verma, the Parliamentary Under Secretary of State for the Department of Energy and Climate Change, emphasised the importance of the UK nuclear supply chain not only for the nuclear renaissance in the UK but across the globe.

Dave's paper focused on technical and service innovation, not just at the contract phase of a project, but early on during project definition and during the Invitation to Tender. Dave explained the 5 positioning techniques used at Aquila Nuclear Engineering, to differentiate the company from the competition.

AWARD OF UNIVERSITY OF MANCHESTER PELLETRON HOT CELLS-

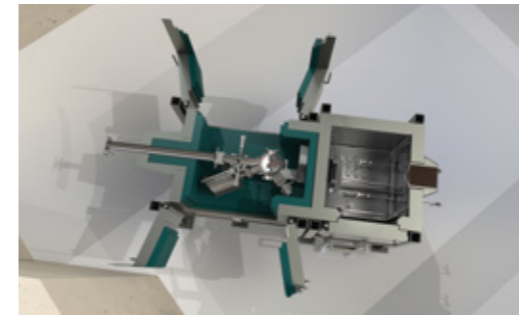

Aquila is progressing with the design, manufacture and installation of Beamline target cells for The Dalton Cumbrian Facility (DCF), part of The University of Manchester.

To facilitate the research, large-scale irradiation

facilities were created at DCF, incorporating a Pelletron 5MV tandem ion accelerator manufactured by National Electrostatics Corporation and a high-energy self-contained 60Co gamma irradiator, along with the requisite post-irradiation examination, experimental equipment.

Aquila Nuclear Engineering Ltd, has won the design and supply contract to provide a shielding solution that allows for an increase in ion beam energy and flux in order to achieve greater levels of radiation penetration and damage in target materials.

Running the Pelletron at higher beam energies increases the neutron radiation during beam operation and creates Gamma radiation by activation of the target material.

The challenge was to provide a shielding solution that provides for:

- High beam line energies and currents over extended periods
- Handling, storage and transportation of activated samples
- Integration into the existing vaults
- Operation within the existing site safety systems and arrangements

Working with the University, a proactive, open and iterative approach was taken to identify and set the design inputs, establish restrictions, explore operational practices to achieve an aligned output. The project includes the design, supply and installation of two cells:-

Target Rig Hot Cell; the working envelope was established to provide futureproofing of beam line end stations, shielding is a combination of a Boron loaded polymer liner (prompt neutron radiation) and an outer lead shield (Gamma activated targets). Access is gained by full width doors on both sides to establish the equipment and initial target set up. Activated targets are collected and transferred from the beam line end station and the adjacent handling hot cell by an automated transfer device.

Handling, Storage and despatch Hot Cell; Activated targets are received into the hot cell via the automated transfer device via a shield door where it can be reversed, inspected, stored for storage, etc. Articulation is via tong sphere units with a lead glass viewing window. An area is available for installation of jigs and fixtures for use in combination with the ting units. Interlocked shielded storage channels are set within the floor to allow activated samples to decay, prior to dispatch into a shielded transport package for transfer off site. Access is gained through a full side opening door.

“ DAVE'S PAPER FOCUSED ON TECHNICAL AND SERVICE INNOVATION, NOT JUST AT THE CONTRACT PHASE OF A PROJECT, BUT EARLY ON DURING PROJECT DEFINITION AND DURING THE INVITATION TO TENDER. ”



AQUILA NUCLEAR ENGINEERING IS THE SOLE UK DISTRIBUTOR FOR GETINGE-LA CALHÈNE PRODUCTS

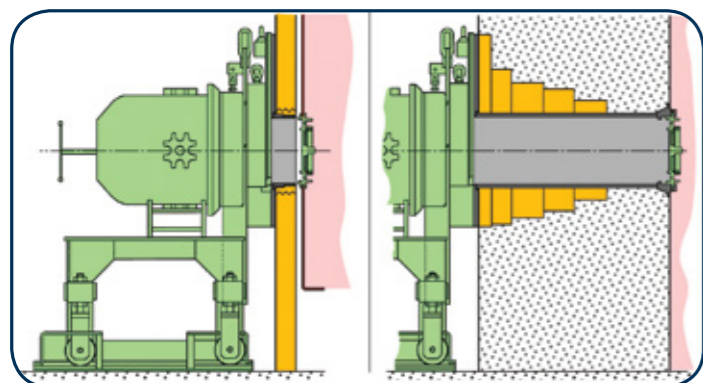

Getinge-La Calhène, has been providing products for the safe handling and transfer of nuclear material for over 50 years. Getinge-La Calhène, supply 3 main types of products:

Manipulators: Used for the remote handling of radioactive material inside glove boxes and shielded cells.

Transport Casks: Used for transport of radioactive material without breaking containment.



A WORD FROM MARK SHAW



“ I JOINED AQUILA WITH THE AIM TO BE A VALUED PLAYER IN A TEAM OF PROFESSIONAL ENGINEERS...”

I joined Aquila with the aim to be a valued player in a team of professional engineers who I could both learn from and contribute to, the Aquila team is just that. Every job is treated as a bespoke project and the focus is always on providing the best possible solution.



Pete Crockford, Tendering Manager, said, “Mark has merged into the commercial team extremely quickly and with guidance, has already secured some contracts from our traditional client base. We see Mark’s contribution to Aquila as pivotal in the development of a younger team of nuclear engineers, taking the business to the next level.”



AQUILA WIN CONTRACT FOR DSRL LEGACY PLUTONIUM AND URANIUM HANDLING FACILITY

A £10m engineering and manufacturing contract is bringing together suppliers from across the UK, with the engineering skills capable of meeting the exacting standards of the nuclear industry. The unirradiated fuel characterisation facility (UFCF) is being assembled and tested before being disassembled and taken to Dounreay for installation in late 2015. These UK companies include the DSRL glovebox framework companies, Aquila Nuclear Engineering, JGC Engineering and Redhall.

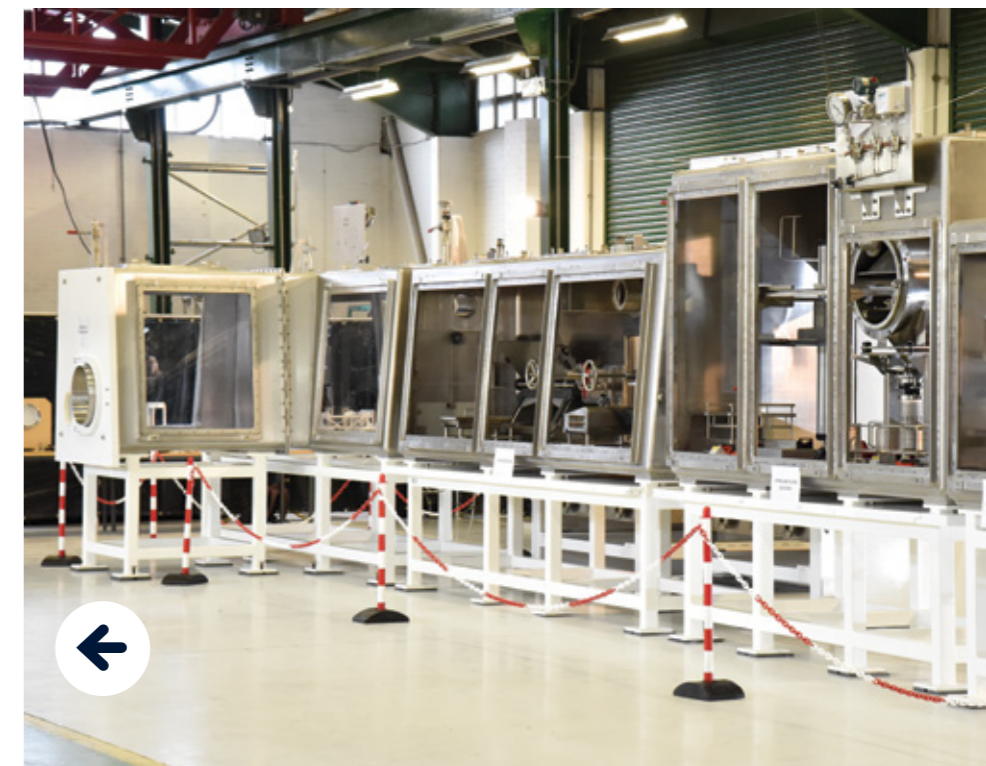

DECOMMISSIONING



ILW RETRIEVAL SOLUTION

Aquila has just completed the design and methodology of installation of an ILW retrieval solution for a suite of Hot Cells. The project included site survey, defining the design model interfaces, detailed scheme design, risk assessment, engineering calculations and methods statements. The solution included a tubed fabrication, shielded gamma gate and interface, double bagging posting. Richard Freeman, an Aquila Project Manager, said, “An elegant design based on proven technology, I can see us employing this solution elsewhere within the nuclear industry.”

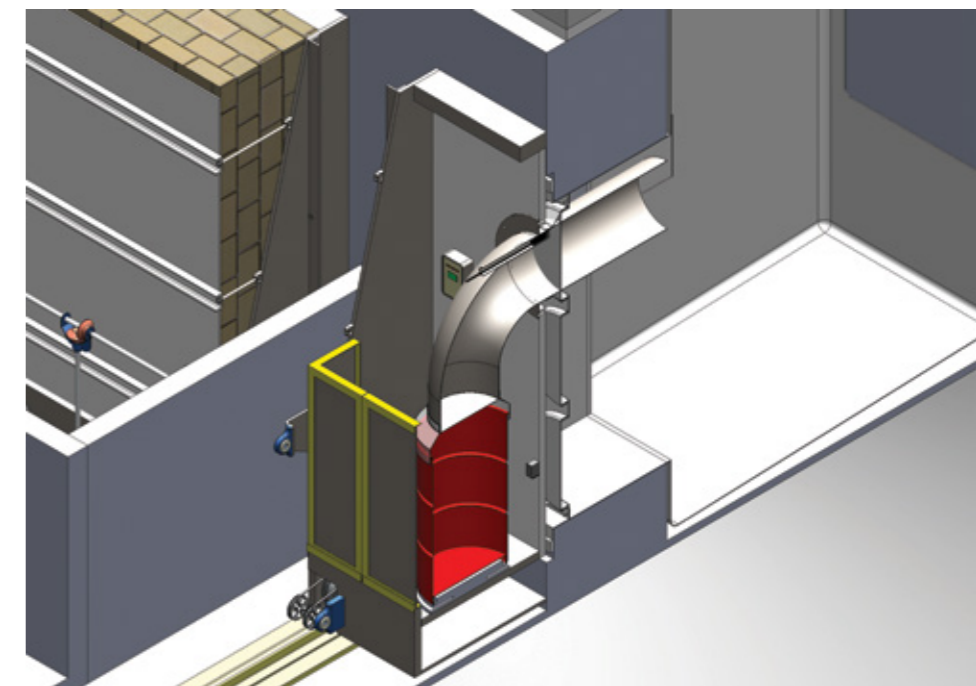

2 ASSAY HANDLING SYSTEMS FOR CANBERRA UK

2 ASSAY HANDLING SYSTEMS WERE DESIGNED AND SUPPLIED BY CANBERRA UK AND AQUILA TO BE INTEGRATED INTO A WASTE RETRIEVAL AND CONDITIONING PROCESS AT DSRL

After initial sorting, waste is packed into drums and assigned a unique profile. The system requirements are to manipulate the drum while alpha and beta/gamma assay measurements are performed to quantify fissionable isotopes of Uranium and Plutonium and allow full actinide inventory of waste packages. Results are added to the drum 'fingerprint' and it remains as a controlled, well defined item, through to final packaging for interim storage.

Canberra provided overall Project Management with DSRL, focusing on the neutron assay and gamma spectroscopy instrumentation and complete systemisation while Aquila provided the design, manufacture and build of all mechanical elements of the system.

AIMS AND OBJECTIVES OF THE PROJECT

The project scope was to design, manufacture, factory test, install and commission, two assay handling systems. Starting with a clean sheet of paper and developing the design to compliment the Canberra UK designed assay systems and maximise their effectiveness.

AQUILA DEMONSTRATE BEST PRACTICE

Aquila began the contract with a feasibility study on methods available to manipulate the drum during assaying. A scheme design was developed employing COTS (commercial off the shelf) items where possible and avoiding novel solutions in line with DSRL TRL (technical readiness level) guidelines. The equipment has a design life of 10 years with limited or no access for maintenance. This presented Aquila with some considerable restrictions which had to be carefully addressed. Meanwhile, Canberra UK, conducted extensive system modelling to determine the arrangement and sensitivity of the assay systems and finalised the shielding and system geometry requirements.

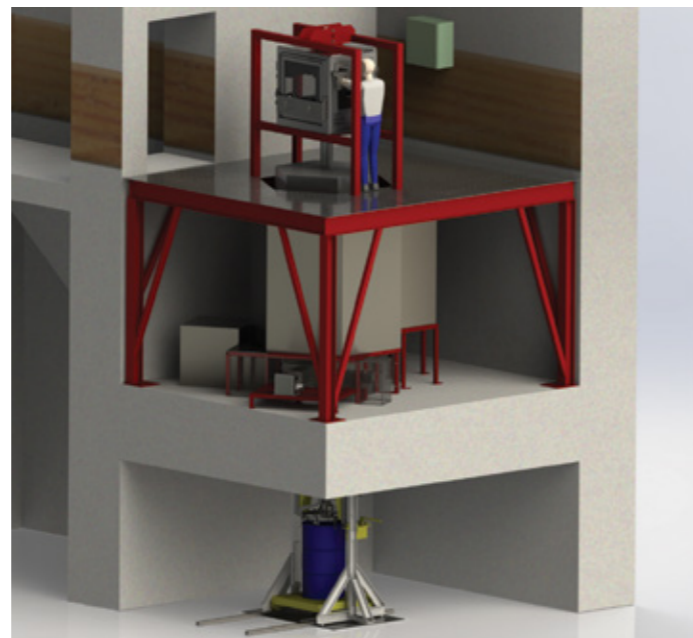

Aquila integrated all these requirements into the design and managed the manufacture, factory and site installations. Canberra UK, and Aquila, held face to face project and design review meetings every month, maintaining excellent communications, ensuring expectations were clear and all actions addressed.

Once Aquila had commissioned the complete handling system in the Canberra UK facility at Harwell Oxfordshire, it handed the plant over for Canberra UK to conduct an extensive programme of active testing and calibration, prior to the plant being installed for the final time in a new facility at DSRL.

AQUILA PARTNERSHIP



AQUILA AND HARGREAVES COMBINE ACTIVE CONTAINMENT KNOWLEDGE AND CAPABILITIES.

Aquila Nuclear Engineering and Hargreaves, are teaming up to identify turnkey opportunities for containment solutions. With Aquila recognised as the principal engineering supplier for glove box technology and Hargreaves as the principal active ventilation suppliers in the UK, it made sense to share best practice to the benefit of our clients. United Kingdom Atomic Energy Authority, was the first client to receive a turnkey solution from both companies.



AQUILA INVESTMENT IN OUR FUTURE



Aquila is sending two engineers to the Nuclear Institute - Young Generation Network (YGN) seminar at EDF later this year. The seminar is going to be held over 3 days at the EDF energy Conference Centre in Barnwood and will provide an excellent opportunity for its people to learn more about the nuclear industry and also a great chance to network with other young professionals.

NEW BUSINESS DEVELOPMENT MANAGER DREW CORBETT

Drew Corbett, joins Aquila Nuclear Engineering Ltd, as our business development manager designate, taking over the reigns fully in December 2015. Drew has an engineering background and will be a regular attendee at the NIA and NI events in the years ahead. Drew said:



"The Aquila team exude a confidence which is underpinned by a depth of nuclear experience and proven management systems. The professionalism that runs throughout the organisation has made my integration both productive and enjoyable. I am looking forward to utilising my business development skills and becoming an integral component of the ongoing success of Aquila."



SOUTHERN MANUFACTURING 2015

DUE TO CONTINUED GROWTH IN THE NUCLEAR AND NUCLEAR MEDICINES MARKET, AQUILA PROMOTED THE EXCITING CHALLENGES AHEAD WITHIN THE NUCLEAR INDUSTRY AT SOUTHERN MANUFACTURING 2015, IN FARNBOROUGH.

Elizabeth Wheeler, Finance and Administration Manager, said, "with 600 stands and plenty of visiting engineers we received a great deal of interest. Although these talented engineers are from outside the nuclear industry they will quickly add value to the business with close guidance from our embedded team of nuclear engineers."



EVENTS

6TH – 10TH JULY 2015

Decommissioning & radioactive waste summer school

10TH – 14TH AUGUST 2015

International conference on structural mechanics in reactor technology

9TH – 11TH SEPTEMBER 2015

WNA symposium 2015

21ST SEPTEMBER 2015

Nuclear operations & DECOMM summit

29TH SEPTEMBER 2015

Work of the ONR

4TH NOVEMBER 2015

NDA Estate supply chain event 2015

FIND OUT MORE

Aquila Nuclear Engineering Ltd

Aquila House,
Hazeley Enterprise Park,
Hazeley Road, Twyford,
Hampshire, SO21 1QA,
United Kingdom

T: +44 (0) 1962 717 000
E: info@aquilaeurope.eu

[linkedin.com/company/2439808](https://www.linkedin.com/company/2439808)

twitter.com/aquilanuclear1



www.aquilaeurope.eu

 A Calder Group Company