

LaCalhene Products

Cyclife Aquila Nuclear is the sole UK distributor for LaCalhene products in the nuclear and nuclear medicines market. LaCalhene has been supplying remote manipulators and transfer systems for the protection of the operator, against alpha particles and gamma radiation since the 1960s.

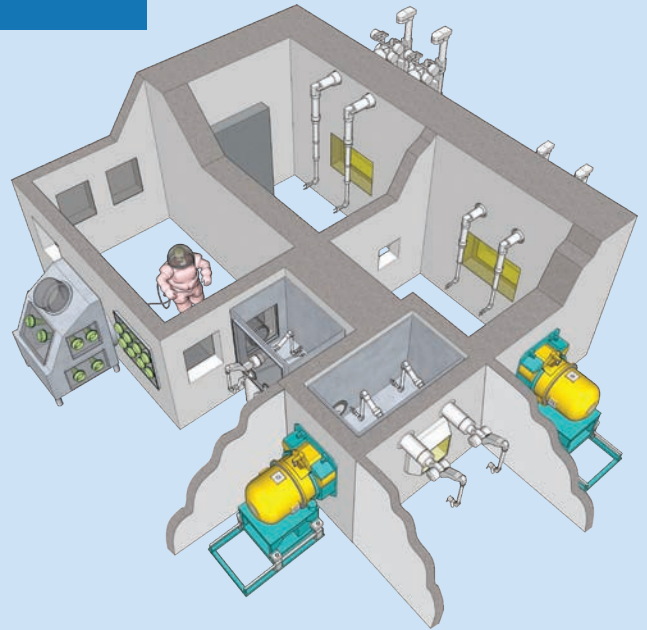

LaCalhene fabricates, installs and services standard and customised equipment for clients within the nuclear industry. This equipment either protects the client's product from the external environment or protects the customer's facilities and personnel from potentially dangerous products.

LACALHENE 

Manipulation

LaCalhene is one of the leading global suppliers of manipulators - a full range of Master Slave Manipulators (MSMs) is available for use in shielded cells and glove systems for use in gloveboxes.



Transportation

LaCalhene offers safety for the environment and nuclear operators. PADIRAC and AGNES are unique systems adopting the use of the DPTE® transfer systems and B(U) packages, that allow safe transfer on site and transportation on public roads, in accordance with the IAEA SS6 regulations.



Transfer

LaCalhene is the world leader for sealed transfer systems. From the first DPTE® system originally designed in the 1960s, LaCalhene has developed a large range of products, providing safe on site transfer and public road transportation, for radioactive material.



The DPTE® transfer system

Secure connection between two enclosures

LaCalhene, the creator of the DPTE® transfer system:

In 1963, LaCalhene developed the first DPTE® Double Door for Leaktight Transfer (Double Porte de Transfert Etanche) transfer system. Continuously improved and used for multiple applications, the DPTE® is the market reference.

With more than 30,000 systems in use around the world, the DPTE® is the industry standard for transfers requiring containment. LaCalhene's engineering office can design bespoke solutions for your project.

The DPTE® system: an ingenious operating principle:

First and foremost a method to prevent breaking containment when transferring a product, the unique DPTE® system is composed of two complementary units, the Alpha and Beta, with mechanical safety locks and opposing seals.

Functioning Principle:

The Alpha and Beta parts join together to form a single unit when they are connected by a 60 degree rotation. At the same time, both doors are detached from their respective flanges and fixed together, while the seals continue to maintain leak tightness of the new connected assembly.

Key: ● - Alpha ● - Beta

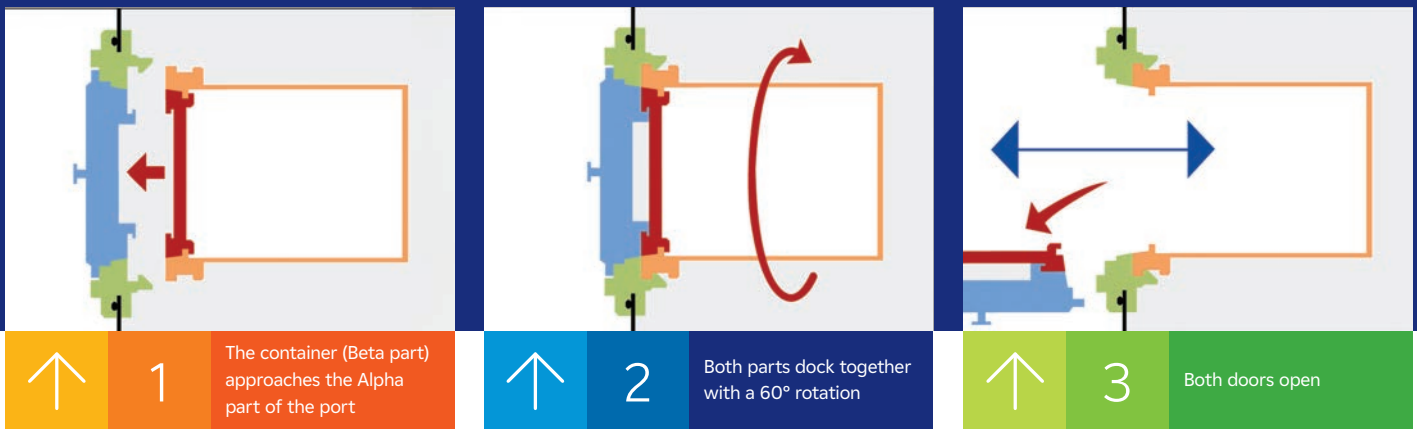

Perfectly adapted

The DPTE® design is perfectly adapted to the nuclear environment:

- Containment maintained at all times.
- Unlimited lifetime for the fixed parts (not including seals which can be replaced without breaking containment).
- Maintenance operations are only required on removable parts (by remote manipulators or gloves, depending on the type of cell/glove box).

Adapted to requirements

A wide range adapted to many requirements:

- Size*: 105, 190, 270 and 460 mm diameter.
- Material: Cell door is stainless steel or polyethylene.
- Cell flange is stainless steel.
- Grip system:
 - Gripping ball (manual opening).
 - Gripping square (for remote manipulator opening).
 - Gripping device (for remote manipulator opening).

Connection Tunnel

The connection tunnel is used for leaktight transfer between two contained volumes.

It is a stainless steel Beta part with a metal bellows connected to a DPTE® Alpha part.



Waste removal

The Nuclear version of the DPTE-BetaBag® is a flexible leaktight solution for extracting contaminated materials.

Connection to a DPTE® port: the DPTE-BetaBag® can remain locked onto the port without risk or be re-connected to different ports as required. The DPTE-BetaBag® 270 PU 95L NS NUC is a large polyurethane bag adapted to a Ø 270 DPTE® Alpha port.



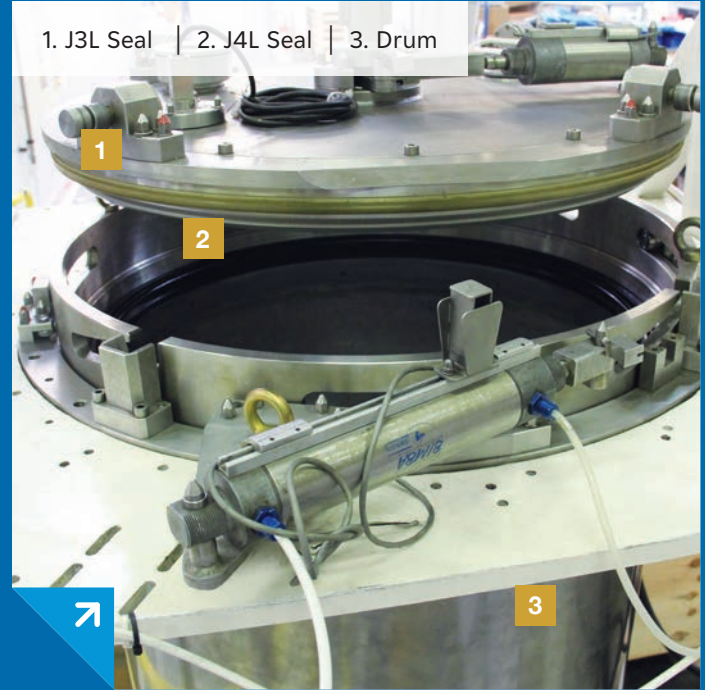
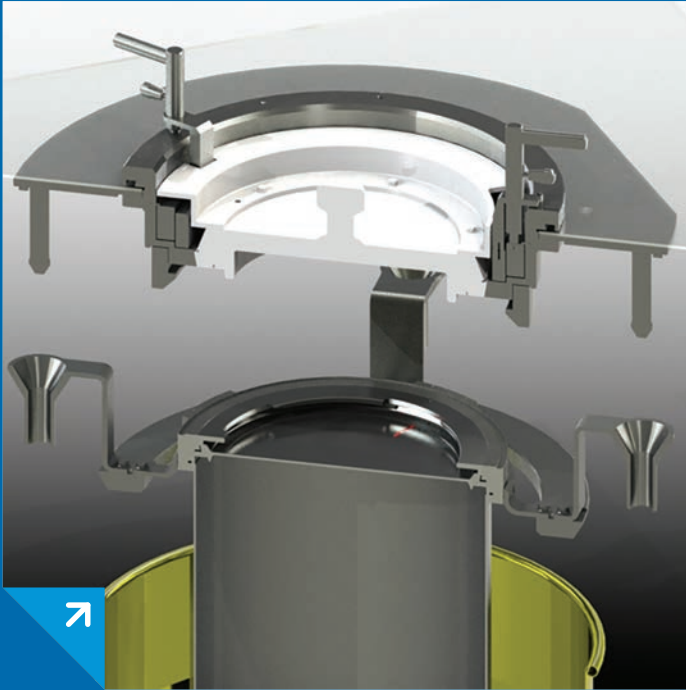

The DPTE-DrumLiner®

A safe, fast, economical system

A rotating double door (DPTE®) system, diameter 270mm for connection to a 120 litre container, or 460mm for connection to a 200 litre (55 US gallons) container (standard oil barrel).

The DPTE-Liner® consists of a standard drum with a DPTE® container housed inside.

Advantages:

- Multiple connections/disconnections.
- Filling ratio is optimised.
- Safe transfer without loss of containment.
- Cost effective.

The CEFE System

A solution for large volume wide diameter transfer applications

The CEFE system is a large, fully assisted DPTE® double door system, providing protection against α , β and γ contamination. It is mainly used in dismantling operations. There is no need to rotate the Beta part (drum) as it is serviced from inside the cell. Maximized loading rates can be achieved in this robust, large drum by waste compaction.

The CEFE system is based on the DPTE® system concept:

- Maintains containment in the cell to which it is connected.
- Provides leak tightness and prevents contamination during drum docking/undocking on the cell.

The CEFE is available in the following versions*:

CEFE 560

- Painted steel drum, 200 litres.
- Stainless steel drum, 220 litres.

CEFE 695

- Stainless steel drum, 440 litres.

*The CEFE drum can be completely customised.

Remote Manipulators

Solutions adapted to all types of hot cells

The nuclear industry requires the use of specific equipment in order to operate and service installations containing radioactive or toxic substances.

LaCalhene offers a complete range of electro-mechanical remote manipulator arms which extend the operator's ability to manipulate in hostile environments.

Powerful and ergonomic, each manipulator and its array of accessories has been designed and manufactured

under strict quality control conditions. Their simple and robust design is the key to keeping maintenance costs low.

A team of qualified technicians is available at Vendome in France or Cyclife Aquila in the UK to service or modify installed equipment. Our Training centres keep customers' operators up to date. Together, we provide a complete service including spare parts supply throughout the lifetime of our products.

Figure 1: large movements

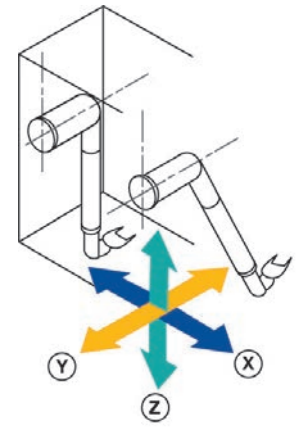
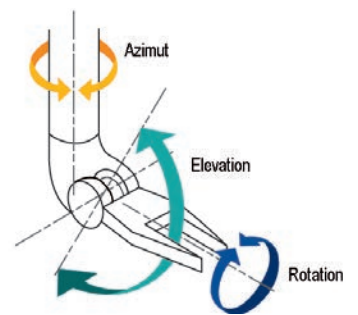

Figure 2: small movements



7 degrees of freedom for optimal manipulation:

- Three positioning degrees (Figure 1).
- Three orienting degrees (Figure 2) and tongs tightening.



MA 11-80

A Master-Slave Manipulator with articulated arms

- Supplied in short, medium and long sizes.
- Nominal load capacity: 6 to 7 daN (depending on version).
- Load capacity at hook: 12 daN.
- For work in glove boxes, small medium size hot cells.
- Non-disconnectable.
- Protective sleeve mounted on BE 22 cell ring.
- Master-Slave electrical offset gives ergonomics that cannot be matched in this range of equipment.

A 30

A Master-Slave Manipulator with articulated arms

- Supplied in short, medium and long sizes.
- Nominal load capacity: 2.5 to 3.5 daN (depending on version).
- Prices manipulation in a 2 to 3 m³ volume.
- Spring-loaded system for efficient balance in the area covered by the slave arm.
- Light, robust manipulator, straightforward to operate.
- Protective sleeve mounted on BE 22 cell ring.

MT 200

A Master-Slave Manipulator with telescopic, disconnectable slave arm

- Several lengths available for both master and slave arms.
- Maximum load capacity: 20 daN.
- Designed for work in medium and large size cells.
- Can be configured and adapted to varying cell dimensions.
- The slave arm can be remotely disconnected from the thru-tube.
- Containment is provided by a sleeve (single or double) or leaktight thru-tube depending on requirements.
- The thru-tube integrates radiation protection.
- Major motions (X, Y and Z) are equipped with electrical offset for better operator comfort and to increase the working range.
- Three mechanical brakes, with controls located at the base of the master arm block movement of the master arm.
- The gripping motion brake is activated by a control integrated in the handle.



MT 120



MT 120

A Master-Slave Manipulator with telescopic arms

- Supplied in short, medium, long and extra-long lengths.
- Nominal load capacity: 12 daN.
- Designed for work in medium size cells.
- Two versions:
 - Non-disconnectable in continuous kinematics.
 - Disconnectable in 2 parts: Master Arm and Thru-tube/ Slave Arm sub-assembly.
- Two thru-tube diameter versions:
 - \varnothing 190.5 (7.5') with BE CC cell ring.
 - \varnothing 254 (10') with BE 88 cell ring.
- Major motions (X and Y) equipped with electrical offset.
- Three mechanical brakes, with controls located at the base of the master arm, block movement of the master arm.
- The gripping motion brake is actuated by a control integrated in the handle.



MT 200 TAO



MT 200 TAO

Computer assisted remote manipulator

- 20 kg capacity in all positions with force feedback.
- Robotic mode for repetitive tasks.
- Poly-articulated Master Arm using haptic technology.
- The Slave Arm can reach the ceiling of the hot cell, multiplying the work volume by 3 compared to the MT 200.
- No electrical or electronic components in the hot cell.
- MTBF*: 2 to 10 times that of the MT 200, depending on the type of work task.
- As well as direct vision work, remote working (up to 200m from the cell) can be done via imaging systems (camera, 3D, etc).



TERMAN TAO



Terman TAO

Computer assisted remote manipulator with enhanced robotic mode

- An exceptionally rigid, resistant, precise and long-lasting slave arm.
- Telescopic slave arm with variable length from 1470 cm to 4100 cm.
- Robotic mode in all positions.
- Highly dexterous thanks to infinite azimuth and infinite rotation on the tongs.
- MTBF*: 1000 hours (reference duty cycle).
- Thru-tube is compatible with LaCalhene remote manipulators, the MT200 and MT200 TAO.



Shielded containers for transporting

Highly contaminated and radio-active materials inside a site and on public roads.

LaCalhene offers a range of unique packaging solutions based on the DPTE® leaktight transfer system, consisting of a shielded container, a DPTE® container and a transport carrier.

The LaCalhene Engineering Design office can study tailor-made solutions for your specific project. The LaCalhene packaging systems offer safe transfer on site and (for

some systems) on public roads in conformity with IAEA (International Atomic Energy Agency) regulations.

The PADIRAC™ RD15 and AGNES are certified (type B certificate).including spare parts supply throughout the lifetime of our products.

ANGES

PADIRAC™ and AGNES

Two casks for transfer and transport on public roads

The PADIRAC™ - A robust, safe transfer solution

The PADIRAC™ is designed to transfer and transport radio-active materials (alpha, beta and gamma emissions) while providing protection against irradiation and maintaining containment. The PADIRAC™ meets international standards for shipment on a public road (type B certification), when encased inside its transport shell.

A complete range of accessories is available for this cask: lifting fork, transport cover, transport shell, cask stand, supporting table, shielded sliding door, actuating rod.

The PADIRAC™ is available in lead thicknesses of 150 and 200 millimeters according to application. The shielded cell door is available with biological protection 50, 100, 200, 250 or 300 millimetres thick.

The cask holds a 20 litre DPTE® 270 container, made of stainless steel or polyethylene depending on the application.



PADIRAC™ Shielded container with transport cover

AGNES - A solution for shipping on public roads, with flexible loading methods

Like the PADIRAC™, the AGNES system offers alpha, beta and gamma protection levels in a single piece of equipment. It contains a cluster holder basket which can be interfaced with a DPTE® 105. AGNES provides operator and environmental security, fast loading and unloading and transport on public roads.

AGNES can be loaded in direct connection on a DPTE® double door as well as in a liquid environment (pool or reactor).

AGNES

A solution for shipping on public roads, with flexible loading methods

Like the PADIRAC™, the AGNES system offers alpha, beta and gamma protection levels in a single piece of equipment.

It contains a cluster holder basket which can be interfaced with a DPTE® 105. AGNES provides operator and environmental security, fast loading and unloading and transport on public roads.

AGNES can be loaded in direct connection on a DPTE® double door as well as in a liquid environment (pool or reactor).



AGNES Shilded container with transport cover



MINI-PADIRAC

Cask for transfer and transport on site

MINI-PADIRAC - A cask for transferring and shipping moderately radio-active materials

The MINI-PADIRAC, is used for applications similar to those of the PADIRAC™ since it holds the same leaktight container, but its lighter shield (25mm thick lead) makes it suitable for less radio-active products. Containment during transfers is provided by a DPTE® 270 container.

The MINI-PADIRAC is used to extract low activity waste (alpha, beta, gamma), bring a new item inside the cell and/or for transferring equipment between two cells.



Contact us

T: +44 (0) 1962 717 000

E: info@cyclifeaquila.com

www.cyclifeaquila.com



Our Accreditations

